



2020

BITEX®

www.bitexhubs.com



www.bitexhubs.com

This is the revolution to make the hubs-unique in the world .

Good quality / Best Service / Customers satisfaction .



INDEX

COMPANY HISTORY	02
	03

PATENTS FREEHUB BODY



Anti-Bite

48HD FOR ROAD

Shimano 11s	Titanium
Shimano 10/11s	Alloy
Campy 11s	Alloy
SRAM XDR 11/12s	Alloy

54HD FOR MTB

Shimano 11s	Titanium
Shimano 10/11s	Alloy
Shimano 10/11s	Alloy 6 pawls working together
Shimano 11s	Steel
SRAM XD 10/11s	Alloy

ROAD BIKE HUBS

STRAIGHT PULL	BX314F BX314R	<i>lightweight</i>	08			
	BX313F BX313R	Titanium	09			
	BX312F BX312R	CenterLock	· BX311F BX311R	10		
	BX308F BX308R	· BX307F BX307R	11			
	BX306FG	· BX306F BX306R	12			
	BX305FN BX305RN	· BX305F BX305R	13			
	BX303FC BX303RC	· BX303F BX303R	14			
	BX301F BX301R	· RSPF RSPR	15			
	J-BEND	BX201F BX201R	CycloCross	· BX106F BX106R	CenterLock	16
		BX103F BX103R	· BX101F BX101R	Touring Bike	17	
		RAF16 RAR16	· RAF12 RAR12	18		
		RAF10 RAR9	· RAF8 RAR8	A702SB	Folding Bike	19

MTB HUBS

STRAIGHT PULL	BX403F BX403R	Boost	<i>lightweight</i>	20		
	BX402F BX402R	Boost	· BX401F BX401R	21		
J-BEND	BX213F BX213R	Super Boost	· BX212F BX212R	Boost	CenterLock	22
	BX213F BX211F	BX211R	Boost	· BX210F BX210R	Boost	23
	BX601F BX602F	Lefty	24			
	BX207F BX207R	For Heavy Duty	· A20M	25		
	BX201FG	· MTF15/20	· MTF10	· MTR12	· MTR12-150	26
	FB-MTF15/20 (135/150mm)	Fat Bike	26			
FB-MTR12 (170/177/190/197mm)	Fat Bike	27				

TRACK HUBS

TKF10	TKR10-D (FIXED / FIXED)	TKR10-S (FIXED / FREE)	28
-------	-------------------------	------------------------	----

TRIKE / RECUMBENT BIKE

DH12N	· DH15N	· DH12M	· DH15M	· DH20M	29
-------	---------	---------	---------	---------	----

WHEEL CHAIR HUBS

DH12NR8	
---------	--

SKEWER

SK-MD01	· SK-MD02	· SK-MS01	30
SK-NO8	· SK-MF46	· SK-R12	31

ENTRY PRODUCTS

A702SQ	A702F	· DL802F	DL803R	32
A771F	A773R	· A772R		

Company

The hub is important because it is the main weight-bearing component of the bike. The weight of bicycle and the rider, with all the rolling forces, bear down on the hubs. Amid today's varied and demanding bicycle-performance requirements. Bitex makes a wide range of bicycle hubs that offer :

- Superior strength & stiffness
- Longest lasting durability & reliability
- Lightest weight
- Smoothest rolling performance
- Best value
- Finest finishing colors



BITEX INDUSTRIAL CO. LTD

www.bitexhubs.com



MADE IN TAIWAN

History



1923

1st Generation

Name of shop : Valisum Bike Shop

The first to offer : Rickshaw(1935)/Tricycle(1948)

1947

2nd Generation

Company Name : Valisum Industrial CO., Ltd.

The first company to develop coaster hub.

1978

3rd & 4th Generation

Company Name : Bitex Industrial Co., Ltd.



2010

4th Generation

6 Pawls System / Patented



2014

54HD MTB Freehub Body

Anti-Bite

2017

Anti-Bite System / Patented

2018

Wonderful year!

Congratulations!

Our distributor CYP got good grades at Italian MTB
And, European championship master1 category.

Congratulations!

Jiri Fikejz won the e-bike challenge race at Bike Festival Garda Trentino.

2019



TITANIUM

technical + innovation



Freehub Body

THE SOUL OF THE BIKE.

Patented



6 Pawls System

Taiwan - M425782

China - ZL 2011 2 04061190

Germany - Nr. 20 2011 051 875.2

USA - US 8,443,951 B1

Anti-Bite

Anti-Bite System

Taiwan - M519075

China - ZL 2015 2 0925200.8

Germany - Nr. 20 2015 106 474

USA - Processing



Features

- 1). Lighter
- 2). Durable : total 6 pawls, 3 pawls one turn, 2 turns work
- 3). Smooth : 54HD(MTB) , 48HD(ROAD) high transmission efficiency
- 4). Easy to replace.
- 5). The price depends on the bearings.

Bearing option

- 1). Steel Bearings
- 2). Stainless Steel Bearings
- 3). Ceramic Bearings
- 4). Japanese Ceramics Bearings

ROAD

48HD



106g ± 5g

NO.: R07-F2C1
Shimano 11s
Titanium



69g ± 5g

NO.: R07T-A2C1
Shimano 10/11s
Alloy



77g ± 5g

NO.: R07T-B2C1
Shimano
Alloy 10/11s



73g ± 5g

NO.: R07-C2C1B
Campy 11s
Alloy



70g ± 5g

NO.: R07-N2L1
SRAM XDR 11/12s
Alloy

MTB

54HD



111g ± 5g

NO.: R07-G2C2
Shimano 11s
Titanium



80g ± 5g

NO.: R07T-M2C2
Shimano 10/11s
Alloy



79g ± 5g

NO.: R07T-M2C2Z
Shimano 10/11s
Alloy

Heavy Duty (6 Pawls working together)



161g ± 5g

NO.: R07-K2A2
Shimano 11s
Steel



72g ± 5g

NO.: R07-D2C2
SRAM XD 11/12s
Alloy

Heavy Duty

FREEHUB BODY

New

SRAM XDR

FOR ROAD REAR HUB

70g / 11s , 12s



FREEHUB BODY



6 Pawls System
Work smooth and high transmission efficiency

Our patented 6-pawl freehub body features two sets of three, large pawls, allowing for faster engagement and greater durability.



How it works

New and improved design.

Two sets of three pawls - six in total - reduction in distance between points of engagement by 50%.

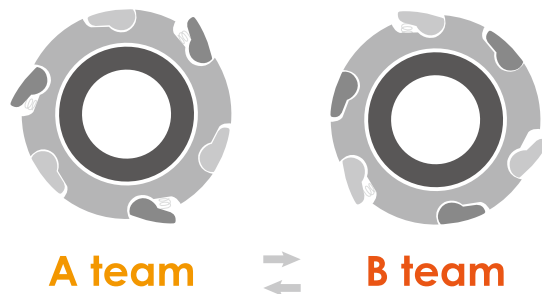

FREEHUB BODY

Anti-Bite Anti-Bite System

One of the most common complaints about Alloy freehub bodies is how easily they can be gouged by cassettes, leaving ugly notches that make removing the cassette difficult. Introducing the new Bitex “Anti-Bite System” - three small, hardened stainless splines to our patented 6-pawl freehub body that will absorb the pressure of the steel cassette. Customers asked for a solution to freehub gouging, and we’ve delivered it.

Innovative design

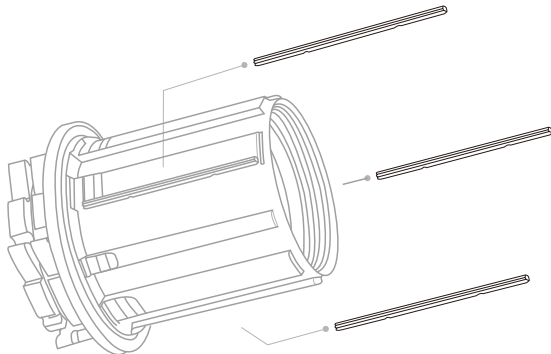

With Anti-Bite



Stainless Splines
x 3

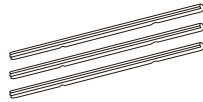

Stainless steel splines on our Shimano freehubs without increasing weight.

ROAD BIKE HUBS

/ The weight is subjected to different specification.

Light Weight



BX314F Straight Pull / Light Weight

Weight	90g ± 5g
Bearings	⊙ 2 (699*2)
Gauge	14
Hole Count	24
Axle system	M9(QR)/100mm
P.C.D	∅ 26.5 - ∅26.5



BX314R Straight Pull / Light Weight

Weight	212g ± 5g
Bearings	⊙ 4 (6802*4)
Gauge	14
Hole Count	24
Axle system	M10(QR)/130mm
P.C.D	∅ 36 - ∅ 49

Free Hub Body Compatible for
Shimano 10 / 11s , Campy , SRAM XDR 11 / 12s

TITANIUM

technical + innovation

**BX313F**

Titanium / Centerlock / Straight Pull

Weight	121g ± 5g (M9/100mm)
Bearings	⊙ 2 (6803*2)
Gauge	14
Hole Count	24
Axle system	M9(QR)/100mm , 12/100mm
P.C.D	∅ 36

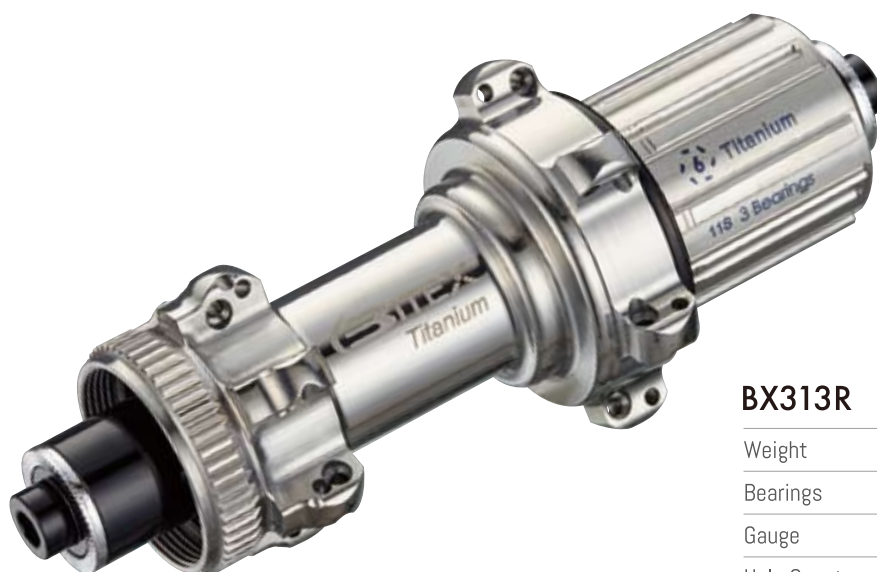
**BX313R**

Titanium / Centerlock / Straight Pull

Weight	278g ± 5g (M10/135mm)
Bearings	⊙ 5 (6802*3+6902*2)
Gauge	14
Hole Count	24
Axle system	M10(QR)/135mm , 12/142mm
P.C.D	∅ 36 - ∅ 49

Free Hub Body Compatible for

Shimano 10 / 11s , Campy , SRAM XDR 11 / 12s

ROAD BIKE HUBS



BX312F

Centerlock / Straight Pull

Weight	97g ± 5g (24H)
	111g ± 5g (28H)
Bearings	◎ 2 (6803*2)
Gauge	14
Hole Count	24, 28
Axle system	M9(QR)/100mm 12/100mm 15/100mm
P.C.D	∅ 36



BX312R

Centerlock / Straight Pull

Weight	186g ± 5g (24H)
	221g ± 5g (28H)
Bearings	◎ 4 (6902*2+6802*2)
Gauge	14
Hole Count	24, 28
Axle system	M10(QR)/135mm 12/135mm 10/135mm 12/142mm
P.C.D	∅ 36 - ∅ 49

Free Hub Body Compatible for
Shimano 10 / 11s , Campy , SRAM XDR 11 / 12s



BX311F

Straight Pull

Weight	85g ± 5g
Bearings	◎ 2 (699*2)
Gauge	14
Hole Count	18, 20
Axle system	M9(QR)/100mm
P.C.D	∅ 28



BX311R

Straight Pull

Weight	222g ± 5g
Bearings	◎ 4 (6802*3+6902*1)
Gauge	14
Hole Count	7/14, 12/12(24)
Axle system	M10(QR)/130mm
P.C.D	∅ 35 - ∅ 51

Free Hub Body Compatible for
Shimano 10 / 11s , Campy , SRAM XDR 11 / 12s

ROAD BIKE HUBS

New generation Road Bike Hub, using innovative carbon bounding technology to allow varieties of hub looks. Straight pull design increases durability. Bigger size of flange increases lateral stiffness. Suitable for routine training.



BX308F Carbon / Aluminum Flanges / Straight Pull

Weight	73g ± 5g
Bearings	◎ 2 (699*2)
Gauge	14
Hole Count	18, 20
Axle system	M9(QR)/100mm
P.C.D	∅ 34



BX308R Carbon / Aluminum Flanges / Straight Pull

Weight	260g ± 5g
Bearings	◎ 4 (6802*2+6902*2)
Gauge	14
Hole Count	7/14, 8/16
Axle system	M10(QR)/130mm
P.C.D	∅ 30 - ∅ 68

Free Hub Body Compatible for
Shimano 10 / 11s , Campy , SRAM XDR 11 / 12s



BX307F Carbon / Aluminum Flanges / Straight Pull

Weight	95g ± 5g
Bearings	◎ 2 (699*2)
Gauge	14
Hole Count	16, 18, 20
Axle system	M9(QR)/100mm
P.C.D	∅ 34



BX307R Carbon / Aluminum Flanges / Straight Pull

Weight	260g ± 5g
Bearings	◎ 4 (6802*2+6902*2)
Gauge	14
Hole Count	7/14, 8/16
Axle system	M10(QR)/130mm
P.C.D	∅ 42 - ∅ 68

Free Hub Body Compatible for
Shimano 10 / 11s , Campy , SRAM XDR 11 / 12s

ROAD BIKE HUBS



BX306FG Straight Pull

Weight	103g ± 5g (15/100mm)		
Bearings	◎ 2 (6803*2)		
Gauge	14		
Hole Count	20, 24		
Axle system	M9(QR)/100mm	12/100mm	15/100mm
P.C.D	ø 36		

BX306FG – New generation Road Bike Hub with disk brake. Straight pull design increases durability. Unlike the traditional caliper brake hubs, this hub provides more powerful brake force and improves braking during poor weather conditions. Suggested for heavier-set riders.



BX306F Straight Pull

Weight	99g ± 5g		
Bearings	◎ 2 (6802*2)		
Gauge	14		
Hole Count	20, 24		
Axle system	M9(QR)/100mm		
P.C.D	ø 32		



BX306R Straight Pull

Weight	219g ± 5g (12/142mm)		
Bearings	◎ 4 (6802*2+6902*2)		
Gauge	14		
Hole Count	24		
Axle system	M10(QR)/135mm	12/135mm	12/142mm
P.C.D	ø 35 - ø 49		

Free Hub Body Compatible for
Shimano 10 / 11s , Campy , SRAM XDR 11 / 12s

ROAD BIKE HUBS

**BX305FN** A7075 / Straight Pull

Weight	66g ± 5g
Bearings	◎ 2 (699*2)
Gauge	14
Hole Count	20
Axle system	M9(QR)/100mm
P.C.D	∅ 28

**BX305RN** A7075 / Straight Pull

Weight	193g ± 5g
Bearings	◎ 4 (6802*4)
Gauge	14
Hole Count	20, 24
Axle system	M10(QR)/130mm
P.C.D	∅ 35 - ∅ 49

Free Hub Body Compatible for
Shimano 10 / 11s , Campy , SRAM XDR 11 / 12s

**BX305F** Straight Pull

Weight	70g ± 5g
Bearings	◎ 2 (699*2)
Gauge	14
Hole Count	20
Axle system	M9(QR)/100mm
P.C.D	∅ 28

**BX305R** Straight Pull

Weight	211g ± 5g
Bearings	◎ 4 (6802*2+6902*2)
Gauge	14
Hole Count	20, 24
Axle system	M10(QR)/130mm M10(QR)/135mm
P.C.D	∅ 35 - ∅ 49

Free Hub Body Compatible for
Shimano 10 / 11s , Campy , SRAM XDR 11 / 12s

ROAD BIKE HUBS



BX303FC Straight Pull

Weight	80g ± 5g
Bearings	⊙ 2 (699*2)
Gauge	14
Hole Count	20
Axle system	M9(QR)/100mm
P.C.D	∅ 28



BX303RC Straight Pull

Weight	228g ± 5g
Bearings	⊙ 4 (6802*2+6902*2)
Gauge	14
Hole Count	24
Axle system	M10(QR)/130mm
P.C.D	∅ 30 - ∅ 52.5

Free Hub Body Compatible for
Shimano 10 / 11s , Campy , SRAM XDR 11 / 12s



BX303F Straight Pull

Weight	75g ± 5g
Bearings	⊙ 2 (699*2)
Gauge	14
Hole Count	18, 20
Axle system	M9(QR)/100mm
P.C.D	∅ 28



BX303R Straight Pull

Weight	233g ± 5g
Bearings	⊙ 4 (6802*2+6902*2)
Gauge	14
Hole Count	7/14, 8/16, 24
Axle system	M10(QR)/130mm
P.C.D	∅ 30 - ∅ 52.5

Free Hub Body Compatible for
Shimano 10 / 11s , Campy , SRAM XDR 11 / 12s

ROAD BIKE HUBS



BX301F Straight Pull

Weight	91g ± 5g
Bearings	◎ 2 (6900*2)
Gauge	14
Hole Count	18, 20
Axle system	M9(QR)/100mm
P.C.D	∅ 30.3



BX301R Straight Pull

Weight	232g ± 5g
Bearings	◎ 4 (6802*2+6902*2)
Gauge	14
Hole Count	7/14, 8/16, 24
Axle system	M10(QR)/130mm
P.C.D	∅ 32 - ∅ 52.5

Free Hub Body Compatible for
Shimano 10 / 11s , Campy , SRAM XDR 11 / 12s



RSPF Straight Pull

Weight	99g ± 5g
Bearings	◎ 2 (6900*2)
Gauge	14
Hole Count	16, 18, 20
Axle system	M9(QR)/100mm
P.C.D	∅ 30.3



RSPR Straight Pull

Weight	218g ± 5g
Bearings	◎ 4 (6802*2+6902*2)
Gauge	14
Hole Count	7/14, 8/16, 24
Axle system	M10(QR)/130mm
P.C.D	∅ 32 - ∅ 52.5

Free Hub Body Compatible for
Shimano 10 / 11s , Campy , SRAM XDR 11 / 12s

ROAD BIKE HUBS



BITEX BX201F Cyclo cross / J-Bend

Weight	133g ± 5g
Bearings	◎ 2 (6802*2)
Gauge	14
Hole Count	20, 24
Axle system	M9(QR)/100mm
P.C.D	∅ 58 - ∅ 45



BITEX BX201R Cyclo cross / J-Bend

Weight	286g ± 5g (M10/135mm)	
Bearings	◎ 4 (6902*3+6802*1)	
Gauge	14	
Hole Count	24, 28	
Axle system	M10(QR)/135mm	12/135mm
	10/135mm	12/142mm
P.C.D	∅ 58	

Free Hub Body Compatible for
Shimano 10 / 11s , SRAM XDR 11 / 12s



BITEX BX106F Centerlock / J-Bend

Weight	131g ± 5g (15/100mm)	
Bearings	◎ 2 (6902*2)	
Gauge	14	
Hole Count	24, 28, 32	
Axle system	M9(QR)/100mm	12/100mm
	15/100mm	
P.C.D	∅ 45	



BITEX BX106R Centerlock / J-Bend

Weight	246g ± 5g (12/142mm)	
Bearings	◎ 4 (6902*3+6802*1)	
Gauge	14	
Hole Count	24, 28, 32	
Axle system	M10(QR)/135mm	12/135mm
	10/135mm	12/142mm
P.C.D	∅ 45 - ∅ 50.6	

Free Hub Body Compatible for
Shimano 10 / 11s , Campy , SRAM XDR 11 / 12s

ROAD BIKE HUBS

**BX103F**

Touring Bike / J-Bend

Weight	205g ± 5g (M9(QR)/100mm)	
Bearings	◎ 4 (6804*4)	
Gauge	14	
Hole Count	28, 32, 36	
Axle system	M9(QR)/100mm	15/100mm
P.C.D	ø 45	

**BX103R**

Touring Bike / J-Bend

Weight	295g ± 5g (M10(QR)/130mm)	
Bearings	◎ 6 (6902*4+6802*2)	
Gauge	14	
Hole Count	28, 32, 36, 40	
Axle system	M10(QR)/130mm	M10(QR)/135mm
P.C.D	ø 58	

Free Hub Body Compatible for
Shimano 10 / 11s , SRAM XDR 11 / 12s

**BX101F**

Touring Bike / J-Bend

Weight	164g ± 5g (15/100mm)	
Bearings	◎ 2 (6804*2)	
Gauge	14	
Hole Count	28, 32, 36	
Axle system	M9(QR)/100mm	15/100mm
P.C.D	ø 45	

**BX101R**

Touring Bike / J-Bend

Weight	275g ± 5g (M10(QR)/130mm)		
Bearings	◎ 4 (6902*3+6802*1)		
Gauge	14		
Hole Count	28, 32, 36, 40		
Axle system	M10(QR)/130mm	10/130mm	12/130mm
	M10(QR)/135mm	10/135mm	12/135mm
			12/142mm
P.C.D	ø 58		

Free Hub Body Compatible for
Shimano 10 / 11s , SRAM XDR 11 / 12s

ROAD BIKE HUBS



RAF16

J-Bend

Weight	116g ± 5g
Bearings	◎ 2 (6000*2)
Gauge	14
Hole Count	20, 24, 28, 32
Axle system	M9(QR)/100mm
P.C.D	∅ 35.5



RAR16

J-Bend

Weight	222g ± 5g
Bearings	◎ 4 (6802*2+6902*2)
Gauge	14
Hole Count	24, 28, 32
Axle system	M10(QR)/130mm M10(QR)/135mm
P.C.D	∅ 50.6

Free Hub Body Compatible for
Shimano 10 / 11s , Campy , SRAM XDR 11 / 12s



RAF12

J-Bend

Weight	82g ± 5g
Bearings	◎ 2 (6900*2)
Gauge	14
Hole Count	20, 24, 28, 32
Axle system	M9(QR)/100mm
P.C.D	∅ 32



RAR12

J-Bend

Weight	207g ± 5g
Bearings	◎ 4 (6802*2+6902*2)
Gauge	14
Hole Count	7/14, 8/16, 24, 28, 32
Axle system	M10(QR)/130mm M10(QR)/135mm
P.C.D	∅ 38.5 - ∅ 50.6

Free Hub Body Compatible for
Shimano 10 / 11s , Campy , SRAM XDR 11 / 12s

ROAD BIKE HUBS



RAF10

J-Bend

Weight	66g ± 5g
Bearings	◎ 4 (688*4)
Gauge	14
Hole Count	16, 18, 20
Axle system	M9(QR)/100mm
P.C.D	∅ 30



RAR9

J-Bend

Weight	192g ± 5g
Bearings	◎ 4 (6802*4)
Gauge	14
Hole Count	7/14, 8/16, 20, 24
Axle system	M10(QR)/130mm M10(QR)/135mm
P.C.D	∅ 38.5 - ∅ 50.6

Free Hub Body Compatible for

Shimano 10 / 11s , Campy , SRAM XDR 11 / 12s



RAF8

Folding Bike / J-Bend

Weight	66g ± 5g (M9/74mm)
Bearings	◎ 2 (699*2)
Gauge	14
Hole Count	16, 18, 20, 24
Axle system	M9(QR)/74mm M9(QR)/85mm M9(QR)/100mm
P.C.D	∅ 30



RAR8

Folding Bike / J-Bend

Weight	202g ± 5g (M10/130mm)
Bearings	◎ 4 (6802*3+6902*1)
Gauge	14
Hole Count	7/14, 8/16, 24, 28
Axle system	M10(QR)/120mm M10(QR)/130mm
P.C.D	∅ 38.5 - ∅ 50.6

Free Hub Body Compatible for

Shimano 10 / 11s , Campy



A702SB

Folding Bike / J-Bend

Weight	151g ± 5g (M9/76mm)
Bearings	◎ 2 (6000*2)
Gauge	14
Hole Count	20, 24, 28, 32
Axle system	M9(QR)/76mm M9(QR)/88mm M9(QR)/100mm
P.C.D	2.5mm - ∅ 35 2.7mm - ∅ 35.5

MTB HUBS

/ The weight is subjected to different specification.

Light Weight



BX403F Boost / Straight Pull

Weight	146g ± 5g
--------	-----------

Bearings	◎ 2 (6903*2)
----------	--------------

Gauge	14
-------	----

Hole Count	24 , 28
------------	---------

Axle system	15/110mm
-------------	----------

P.C.D	ø 43 - ø 43
-------	-------------



BX403R Boost / Straight Pull

Weight	261g ± 5g
--------	-----------

Bearings	◎ 4 (6902*2+6802+6902)
----------	------------------------

Gauge	14
-------	----

Hole Count	24 , 28
------------	---------

Axle system	12/148mm
-------------	----------

P.C.D	ø39 - ø52
-------	-----------

Free Hub Body Compatible for
Shimano 10 / 11s , SRAM XD 11 / 12s

MTB HUBS



Super Boost

BX213F J-Bend

Weight	141g ± 5g
Bearings	◎ 2 (6805*2)
Gauge	14
Hole Count	28, 32
Axle system	20/110mm
P.C.D	∅ 58 - ∅ 49



Super Boost

BX213R J-Bend

Weight	309g ± 5g
Bearings	◎ 4 (6902*3+6802*1)
Gauge	14
Hole Count	28, 32
Axle system	12/157mm
P.C.D	∅ 58

Free Hub Body Compatible for
Shimano 10 / 11s , SRAM XD 11 / 12s



BX212F Centerlock / J-Bend

Weight	142g ± 5g (M9/110mm)
Bearings	◎ 2 (6902*2)
Gauge	14
Hole Count	28, 32
Axle system	M9(QR)/110mm 12/110mm 15/110mm
P.C.D	∅ 58 - ∅ 45



BX212R Centerlock / J-Bend

Weight	267g ± 5g
Bearings	◎ 4 (6902*3+6802*1)
Gauge	14
Hole Count	28, 32
Axle system	12/148mm
P.C.D	∅ 58 - ∅ 58

Free Hub Body Compatible for
Shimano 10 / 11s , SRAM XD 11 / 12s

MTB HUBS



BX211F

Boost / J-Bend

Weight	141g ± 5g
Bearings	◎ 2 (6903*2)
Gauge	14
Hole Count	28, 32
Axle system	15/110mm
	 
	15M 15M FOR ROCKSHOX
P.C.D	∅ 58 - ∅ 45



BX211R

Boost / J-Bend Light Weight

Weight	283g ± 5g (12/148mm)
Bearings	◎ 4 (6902*3+6802*1)
Gauge	14
Hole Count	28, 32
Axle system	12/148mm 12/148mm (Cr-Mo)
P.C.D	∅ 58
	Free Hub Body Compatible for Shimano 10 / 11s , SRAM XD 11 / 12s



BX210F

Boost / J-Bend

Weight	179g ± 5g
Bearings	◎ 2 (6804*2)
Gauge	14
Hole Count	28, 32
Axle system	15/110mm
P.C.D	∅ 58 - ∅ 45



BX210R

Boost / J-Bend

Weight	342g ± 5g (12/148mm)
Bearings	◎ 4 (6902*3+6802*1)
Gauge	14
Hole Count	28, 32
Axle system	12/148mm 12/148mm (Cr-Mo)
P.C.D	∅ 58
	Free Hub Body Compatible for Shimano 10 / 11s , SRAM XD 11 / 12s

MTB HUBS



BX207F

For Heavy Duty / J-Bend

Weight	216g ± 5g (15/100mm)		
Bearings	◎ 4 (6804*4)		
Gauge	14		
Hole Count	24, 28, 32		
Axle system	M9(QR)/100mm	12/100mm	15/100mm
P.C.D	ø 58 - ø 45		



BX207R

For Heavy Duty / J-Bend

Weight	380g ± 5g (12/142mm)		
Bearings	◎ 6 (6902*4+6802*2)		
Gauge	14		
Hole Count	24, 28, 32		
Axle system	M10(QR)/135mm	12/135mm	10/135mm
		12/142mm	12/142mm (Cr-Mo)
P.C.D	ø 58		

Free Hub Body Compatible for
Shimano 10 / 11s , SRAM XD 11 / 12s



BX601F 100mm

BX602F 110mm

Lefty Hubs / J-Bend

Weight	BX601F - 117g ± 5g BX602F - 120g ± 5g		
Bearings	◎ 2 (6805*1+6902*1)		
Gauge	14		
Hole Count	28, 32		
O.L.D	BX601F-100mm BX602F-110mm		
P.C.D	ø 58 - ø 45		



A20M

J-Bend

Weight	237g ± 5g		
Bearings	◎ 2 (6805*2)		
Gauge	14		
Hole Count	24, 28, 32, 36		
ID	20mm		
P.C.D	ø 58		

MTB HUBS



BX201FG

J-Bend

Weight	116g ± 5g (12/100mm)
Bearings	◎ 2 (6803*2)
Gauge	14
Hole Count	24, 28, 32
Axle system	M9(QR)/100mm 12/100mm 15/100mm
P.C.D	ø 58 - ø 45



MTF15/20

J-Bend

Weight	177g ± 5g (20/110mm)
Bearings	◎ 2 (6804*2)
Gauge	14
Hole Count	24, 28, 32, 36
Axle system	M9(QR)/100mm 15/100mm 9/100mm 15/110mm 12/100mm 20/110mm
P.C.D	ø 58 - ø 45



MTF10

J-Bend

Weight	165g ± 5g
Bearings	◎ 2 (6902*2)
Gauge	14
Hole Count	24, 28, 32, 36
Axle system	M9(QR)/100mm
P.C.D	ø 58



MTR12

J-Bend

Weight	268g ± 5g (12/135mm)
Bearings	◎ 4 (6902*3+6802*1)
Gauge	14
Hole Count	24, 28, 32, 36
Axle system	M10(QR)/135mm 12/142mm 10/135mm 12/142mm (Cr-Mo) 12/135mm
P.C.D	ø 58

Free Hub Body Compatible for
Shimano 10 / 11s , SRAM XD 11 / 12s



MTR12-150

J-Bend

Weight	292g ± 5g (M10/150mm)
Bearings	◎ 4 (6902*3+6802*1)
Gauge	14
Hole Count	28, 32
Axle system	M10(QR)/150mm 12/150mm 10/150mm
P.C.D	ø58

Free Hub Body Compatible for
Shimano 10 / 11s , SRAM XD 11 / 12s

MTB HUBS



FB-MTF15/20-135 Fat Bike / 135mm / J-Bend

Weight	245g ± 5g (M9/135mm)	
Bearings	◎ 2 (6804*2)	
Gauge	14	
Hole Count	28, 32, 36	
Axle system	M9(QR)/135mm	15/135mm
	12/135mm	20/135mm
P.C.D	ø 58	

FB-MTF15/20-150 Fat Bike / 150mm / J-Bend

Weight	264g ± 5g (M9/150mm)	
Bearings	◎ 2 (6804*2)	
Gauge	14	
Hole Count	28, 32, 36	
Axle system	M9(QR)/150mm	15/150mm
	12/150mm	20/150mm
P.C.D	ø 58	

Skewer SPEC. Option

QR | Skewer

M10*148.5mm(OLD:135mm)-Front
 M10*167mm(OLD: 150mm)-Front
 M10*190mm(OLD:170mm)-Rear
 M10*210mm(OLD:190mm)-Rear

QR | Skewer : For Sram(w/o. Nut)

12M*167B(OLD:135mm)-Front
 12M*202B(OLD:170mm)-Rear
 12M*209B(OLD:177mm)-Rear
 12M*220B(OLD:190mm)-Rear
 12M*229B(OLD:197mm)-Rear

SIZE | Skewer : For Shimano(W/Nut)

12M*165B(OLD:135mm)-Front
 12M*200B(OLD:170mm)-Rear
 12M*207B(OLD:177mm)-Rear
 12M*220B(OLD:190mm)-Rear
 12M*227B(OLD:197mm)-Rear



MTB HUBS

FB-MTR12-170 Fat Bike / 170~177mm / J-Bend

Weight	323g ± 5g (M10/170mm)	
Bearings	◎ 4 (6902*3+6802*1)	
Gauge	14	
Hole Count	28, 32, 36	
Axle system	M10(QR)/170mm	12/170mm
	M10(QR)/177mm	12/177mm
P.C.D	ø 58	

Free Hub Body Compatible for
Shimano 10 / 11s , SRAM XD 11 / 12s

FB-MTR12-190 Fat Bike / 190~197mm / J-Bend

Weight	340g ± 5g (M10/190mm)	
Bearings	◎ 4 (6902*3+6802*1)	
Gauge	14	
Hole Count	28, 32, 36	
Axle system	M10(QR)/190mm	12/190mm
	M10(QR)/197mm	12/197mm
P.C.D	ø 58	

Free Hub Body Compatible for
Shimano 10 / 11s , SRAM XD 11 / 12s

TRACK HUBS / The weight is subjected to different specification.



TKF10

Weight	222g ± 5g
Bearings	◎ 2 (6000*2)
Gauge	14
Hole Count	20, 24, 28, 32, 36
O.L.D	100mm
Axle	M9(hollow axle) 、 3/8"*140mm(solid axle)
P.C.D	ø 61.4



TKR10-D Fixed / Fixed

Weight	272g ± 5g
Bearings	◎ 2 (6000*2)
Gauge	14
Hole Count	20, 24, 28, 32, 36
O.L.D	120mm
Axle	M10(hollow axle) 、 3/8"*165mm(solid axle)
P.C.D	ø 61.4



TKR10-S Fixed / Free

Weight	272g ± 5g
Bearings	◎ 2 (6000*2)
Gauge	14
Hole Count	20, 24, 28, 32, 36
O.L.D	120mm
Axle	M10(hollow axle) 、 3/8"*165mm(solid axle)
P.C.D	ø 61.4

COG						Lock Ring
Type A	Type B	Type C	Type D	Type E	Type Light	
SPHC-PO NO : B100701 16T / t = 3.0 56g <hr/> NO : B100703 17T / t = 2.8 60g <hr/> NO : B100705 18T / t = 2.8 70g	SPHC-PO NO : B100704 17T / t = 2.2 56g <hr/> NO : B100706 18T / t = 2.2 65g	SUS304 NO : B100708 18T / t = 2.2 54g	SPCC-PO 22T / t = 2.3 86g	SPCC-PO 21T / t = 2.3 79g	SCM430 16T / t = 3.0 45g	SPCC-PO T = 5.0 18.5g

/ The weight is subjected to different specification.

TRIKE / RECUMBENT BIKE

Steinrikes Co. Viktor Horvatski and Robert Stein

The narrow DH12N hub for trikes that it is designed by Steinrikes for "16-18-20" wheels.



DH12N

Weight	210g ± 5g
Bearings	◎ 2 (6001*2)
Gauge	14
Hole Count	20, 24, 28, 32
ID	12mm
Flange C-C	34mm
P.C.D	∅ 57

DH15N

Weight	210g ± 5g
Bearings	◎ 2 (6902*2)
Gauge	14
Hole Count	20, 24, 28, 32
ID	15mm
Flange C-C	34mm
P.C.D	∅ 57



DH12M

Weight	214g ± 5g
Bearings	◎ 2 (6001*2)
Gauge	14
Hole Count	28, 32, 36
ID	12mm
Flange C-C	58.5mm
P.C.D	∅ 57

DH15M

Weight	243g ± 5g
Bearings	◎ 2 (6902*2)
Gauge	14
Hole Count	28, 32, 36
ID	15mm
Flange C-C	58.5mm
P.C.D	∅ 57



DH20M

Weight	220g ± 5g
Bearings	◎ 2 (6805*1+6904*1)
Gauge	14
Hole Count	28, 32, 36
ID	20mm
P.C.D	∅ 57

Axle For DH20M With End Cap

Weight	83g ± 5g
Length	160mm

WHEEL CHAIR HUBS



DH12NR8

Weight	210g ± 5g
Bearings	◎ 2 (R8*2)
Gauge	14
Hole Count	20, 24, 28, 32
ID	12.7mm (R8*2)
Flange C-C	34mm
P.C.D	∅ 57.5

Axle For DH12NR8

Weight	QR - 185g ± 5g
	Nut - 133g ± 5g

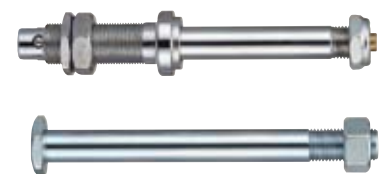

SKEWER

/ The weight is subjected to different specification.



SK-MD01 Titanium Axle Skewer

Weight 45g ± 5g (F+R)

Axle Material Titanium

Lever Material A7075

Parts Material A7075

Color ■



SK-MD02 Titanium Axle Skewer

Weight 44g ± 5g (F+R)

Axle Material Titanium

Lever Material A7075

Parts Material A7075

Color ■



SK-MS01 Titanium Axle Skewer

Weight 44g ± 5g (F+R)

Axle Material Titanium

Lever Material A7075

Parts Material A7075

Color ■



SK-NO8 Cr-Mo Axle Skewer

Weight 110g ± 5g (F+R)

Axle Material Cr-Mo

Parts Material A6061

Color ■

SKEWER



SK-MF46 Cr-Mo Axle Skewer

Weight	125g ± 5g (F+R)
Axle Material	Cr-Mo
Parts Material	A6061
Color	■



SK-MF42 Cr-Mo Axle Skewer

Weight	118g ± 5g (F+R)
Axle Material	Cr-Mo
Parts Material	A6061
Color	■



SK-R12 For MTB Axle 12mm

Weight	80g ± 5g - Skewer for SRAM 88g ± 5g - Skewer for Shimano
Color	■

This Skewer used for MTB Rear Hubs when with Axle 12mm.



SK-FB172 SK-FB174 For MTB Axle 12mm

Weight	33g ± 5g
--------	----------

This Skewer used for MTB Rear Hubs when with Axle 12mm.

ENTRY

/ The weight is subjected to different specification.

A702SQ Folding Bike / Front

Weight	151g
Bearings	◎ 2 (6000*2)
Gauge	14
Hole Count	20, 24
O.L.D	74mm, 76mm
Flange C-C	46.5mm
Axle	M9 x 84mm
P.C.D	ø 35
Color	<input type="checkbox"/> <input type="checkbox"/>



A702F Folding Bike / Front

Weight	155g
Bearings	◎ (Loose Balls)
Gauge	14
Hole Count	24, 28, 32
O.L.D	76mm
Flange C-C	46.5mm
Axle	3/8" x 115mm
P.C.D	ø 35
Color	<input type="checkbox"/> <input type="checkbox"/>



DL802F MTB / Front

Weight	293g
Bearings	◎ (Loose Balls)
Gauge	14
Hole Count	32, 36, 48
O.L.D	100mm
Axle	3/8" {QR Type : M10}
P.C.D	ø 60
Color	



DL803R MTB / Rear

Weight	363g
Bearings	◎ (Loose Balls)
Gauge	14
Hole Count	32, 36, 48
O.L.D	135mm
Axle	3/8" {QR Type : M10}
P.C.D	ø 60
Color	<input type="checkbox"/>



A771F MTB / BMX / Front

Weight	200g
Bearings	◎ (Loose Balls)
Gauge	14
Hole Count	24, 28, 32, 36
O.L.D	100mm
Axle	3/8" {QR Type : M9}
P.C.D	ø 35
Color	<input type="checkbox"/> <input type="checkbox"/>



A773R MTB / Rear

Weight	308.5g
Bearings	◎ (Loose Balls)
Gauge	14
Hole Count	24, 28, 32, 36
O.L.D	126mm, 130mm, 135mm
Axle	3/8" {QR Type : M10}
P.C.D	ø 45.5
Color	<input type="checkbox"/> <input type="checkbox"/>



A772R BMX / Rear

Weight	300g
Bearings	◎ (Loose Balls)
Gauge	14
Hole Count	24, 28, 32, 36
O.L.D	112mm, 114mm
Axle	3/8" {QR Type : M10}
P.C.D	ø 45.5
Color	<input type="checkbox"/> <input type="checkbox"/>





MADE IN TAIWAN



BITEX INDUSTRIAL CO., LTD.

Tel	886 4 2452 7696
Fax	886 4 2452 7096
E-mail	min@bitexhubs.com
Website	www.bitexhubs.com
Add	<i>Office</i> No.48, Ln. 29, Fongming St., Situn Dist., Taichung 40744, Taiwan
	<i>Factory</i> No.140-1, Nanmei Ln., Hesheng St., Shigang Dist., Taichung City 422, Taiwan

Design & Printing by www.molic.com

